

BASIC DESCRIPTION

UD line gear-hydrogenerators as well as UMD line motors are – as regards their structure and the geometric volume range – based on the well-proven line UC (UN). The flange and cover of this hydrogenerators are made of grey case iron; the body is made of an aluminum alloy shaped cross-section bar. The hydrogenerators are connected by means of four M12 through-bolts made of high-strength steel. They are equipped with a hydraulic pressure axial play compensation, which is executed by means of a shape sealing directly in the bearing faces. Compared to the previous design of UC (UN), the UD line hydrogenerators have better parameters of noise, maximum pressure and flow efficiency within the entire speed range, whereas the favorable price has been maintained. The UD line disposes of a wide size range of geometric volumes $V_g = 5$ to $40 \text{ cm}^3/\text{rev}$ while achieving nominal working pressures of up to 30 MPa. The pumps have been produced in one-way as well as multiple versions.

UD gear pumps can be equipped with flow control and a safety valve.

For special purposes, a reinforced version (UDD) or a short version (UDK) pumps are available.

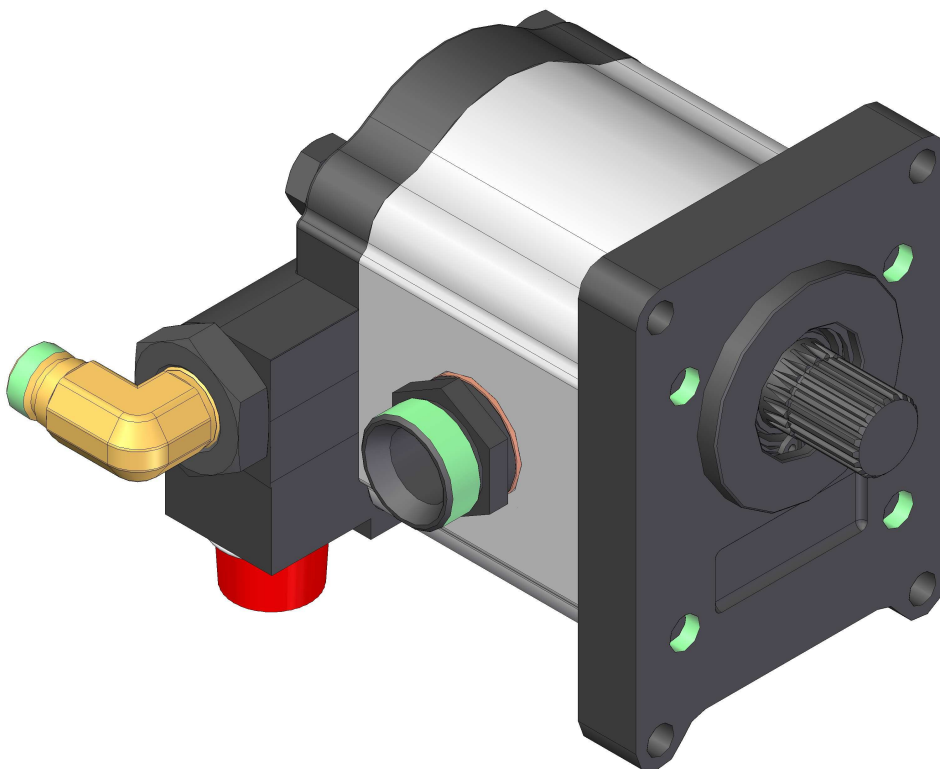

PARAMETER TABLE

Nominal Size Parameters		Symb.	Unit	UD-8,0	UD-10,0	UD-12,5	UD-16,0	UD-20,0	UD-25,0	UD-28,0	UD-31
Nominal displacement		V_g	[cm ³]	8	10	12,5	16	20	25	28	31
Rotation speed	nominal	n_n	[min ⁻¹]	1500							
	min.	n_{min}	[min ⁻¹]	600	450	450	450	450	450	450	450
	max.	n_{max}	[min ⁻¹]	3200	3200	3200	3200	3200	3200	3000	2800
Pressure at the inlet port	max.	p_{1min}	[bar]	0,50							
	min.	p_{1max}	[bar]	-0,30							
Pressure at the outlet port	max. continuous pressure	p_{2n}	[bar]	250	250	250	250	230	200	200	160
	max. pressure	p_{2max}	[bar]	300	300	300	290	270	250	230	200
	peak pressure	p_3	[bar]	310	310	310	300	280	260	240	210
Nominal flow rate (min.) at n_n and p_{2n}		Q_n	[dm ³ .min ⁻¹]	10,70	13,60	16,40	22,00	28,00	35,10	39,10	44,40
Maximum flow rate at n_{max} and p_{2max}		Q_{max}	[dm ³ .min ⁻¹]	25,12	31,74	38,33	51,58	64,79	80,66	84,29	89,09
Nominal input power (max.) at n_n and p_{2n}		P_n	[kW]	5,83	7,37	8,90	11,97	13,83	14,98	16,69	15,12
Max. input power at n_{max} and p_{2max}		P_{max}	[kW]	15,42	19,49	23,54	30,64	35,93	41,53	40,07	37,06
Weight		m	[kg]	5,15	5,30	5,40	5,55	5,70	5,85	6,00	6,20

SUPPLEMENTAL TABLE

Nominal Size Parameters		Symb.	Unit	UD-5	UD-39	UDD-39					
Nominal displacement		V_g	[cm ³]	5	39	39					
Rotation speed	nominal	n_n	[min ⁻¹]	1500	1200	1200					
	min.	n_{min}	[min ⁻¹]	600	400	400					
	max.	n_{max}	[min ⁻¹]	3200	1800	1800					
Pressure at the inlet port	max.	p_{1min}	[bar]	0,50							
	min.	p_{1max}	[bar]	-0,30							
Pressure at the outlet port	max. continuous pressure	p_{2n}	[bar]	250	120	160					
	max. pressure	p_{2max}	[bar]	300	160	170					
	peak pressure	p_3	[bar]	310	170	180					
Nominal flow rate (min.) at n_n and p_{2n}		Q_n	[dm ³ .min ⁻¹]	6,60	44,20	43,50					
Maximum flow rate at n_{max} and p_{2max}		Q_{max}	[dm ³ .min ⁻¹]	15,84	71,40	70,70					
Nominal input power (max.) at n_n and p_{2n}		P_n	[kW]	3,68	14,14	17,68					
Max. input power at n_{max} and p_{2max}		P_{max}	[kW]	9,73	24,04	24,77					
Weight		m	[kg]	5,00	6,55	7,20					

BASIC FLOW CONTROL SETTINGS

Maximum flow: 13 dm³.min⁻¹
 17 dm³.min⁻¹
 20 dm³.min⁻¹
 30 dm³.min⁻¹

BASIC PARTS

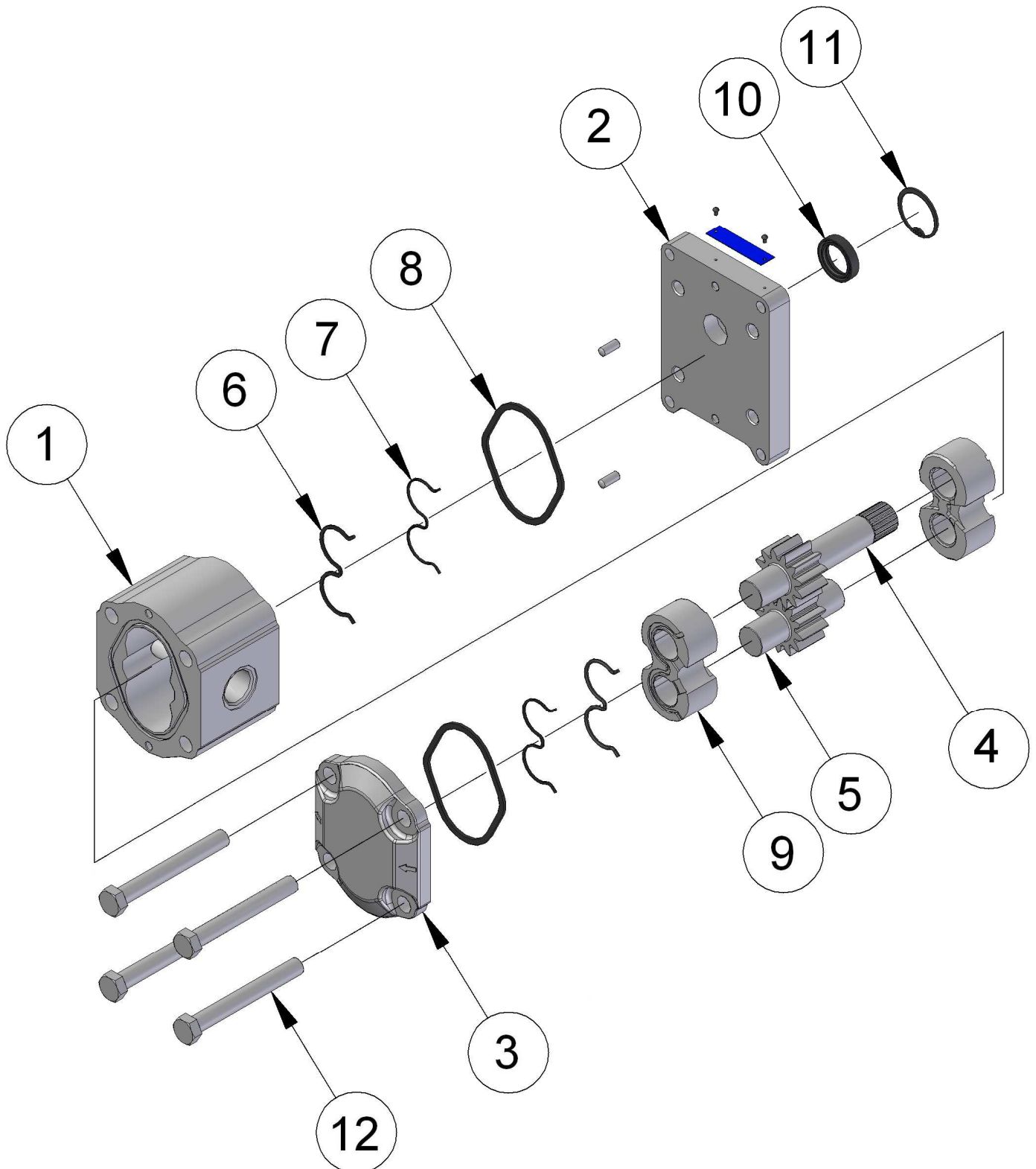

- | | |
|-------------------------|-----------------------------|
| 1. Body | 7. Sealing protective plate |
| 2. Flange | 8. Peripheral sealing |
| 3. Cover | 9. Bearing |
| 4. Driving gear | 10. Shaft seal |
| 5. Driven gear | 11. Safety ring |
| 6. Thrust pressure seal | 12. Connection bolts |

FLOW RATE AND INPUT POWER CURVES

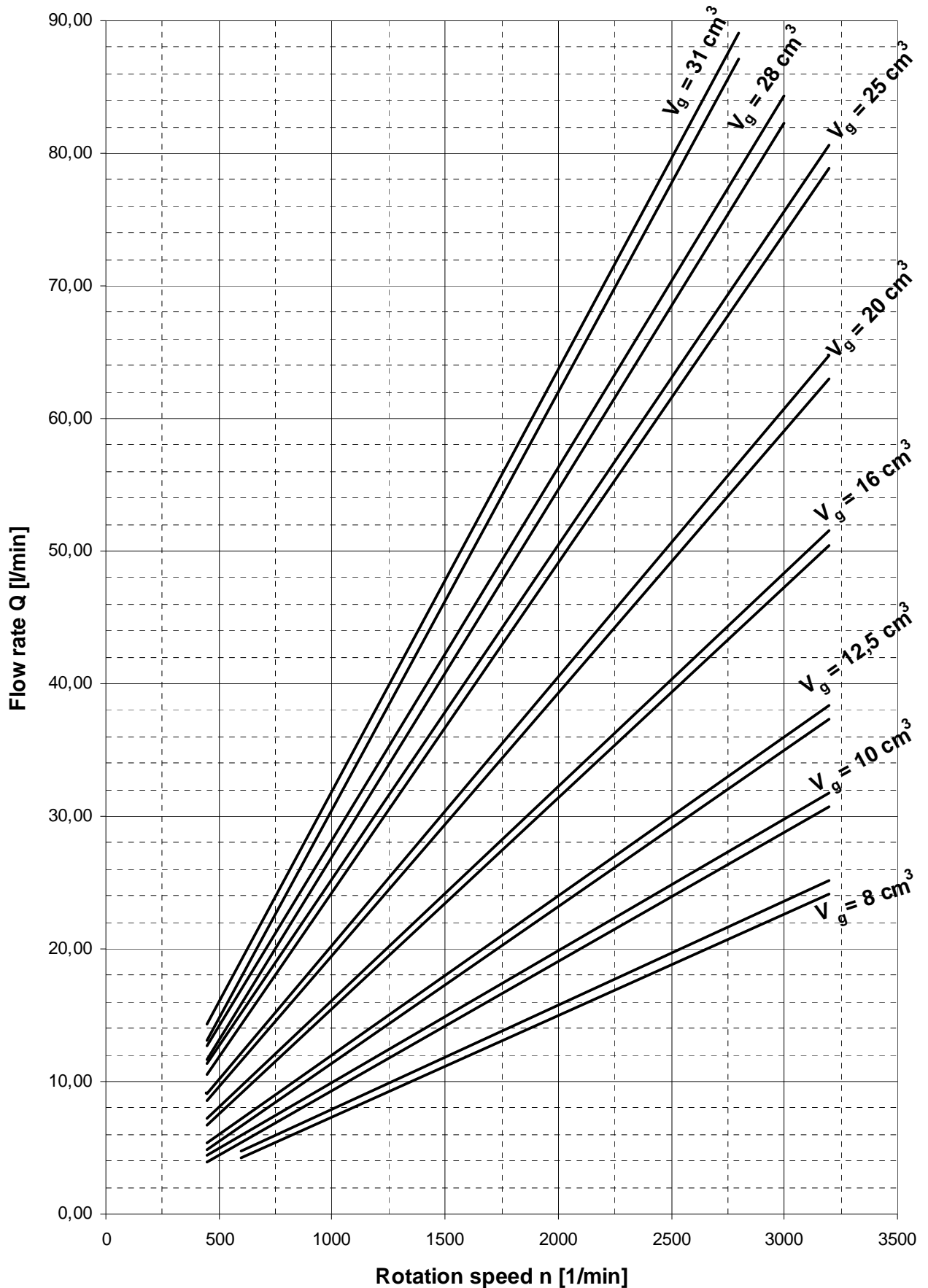

The curves above are valid for the ISO Vg 46 oil at temperature $t = 45^{\circ}\text{C}$.

8 cm³

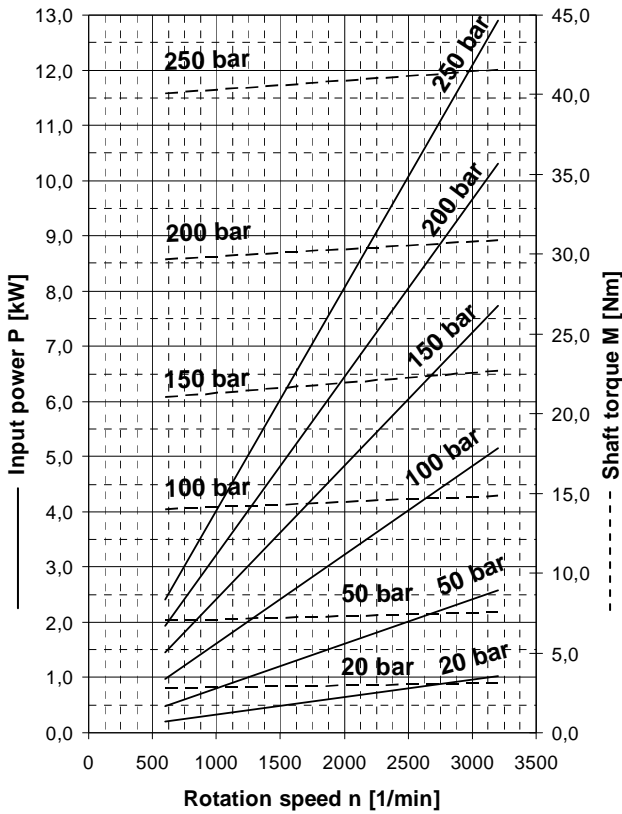

10 cm³

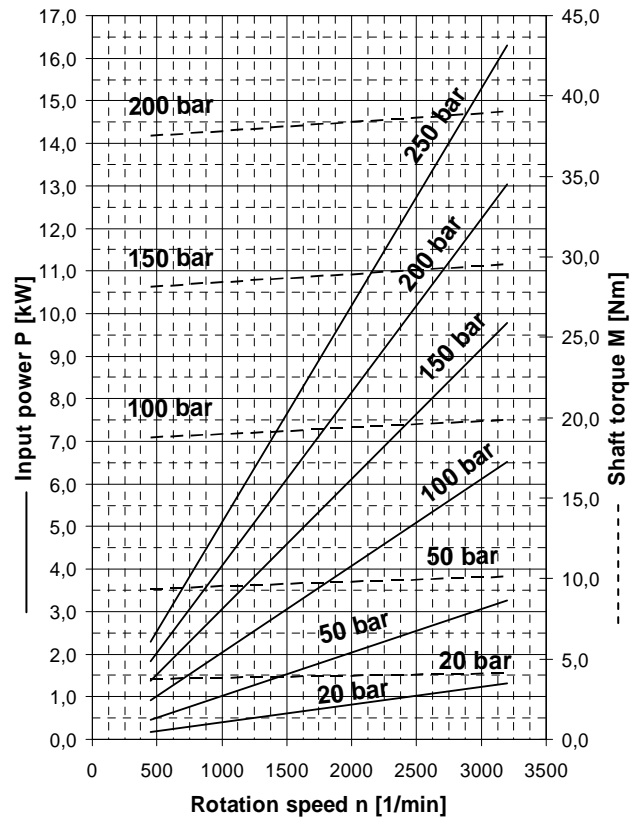

12,5 cm³

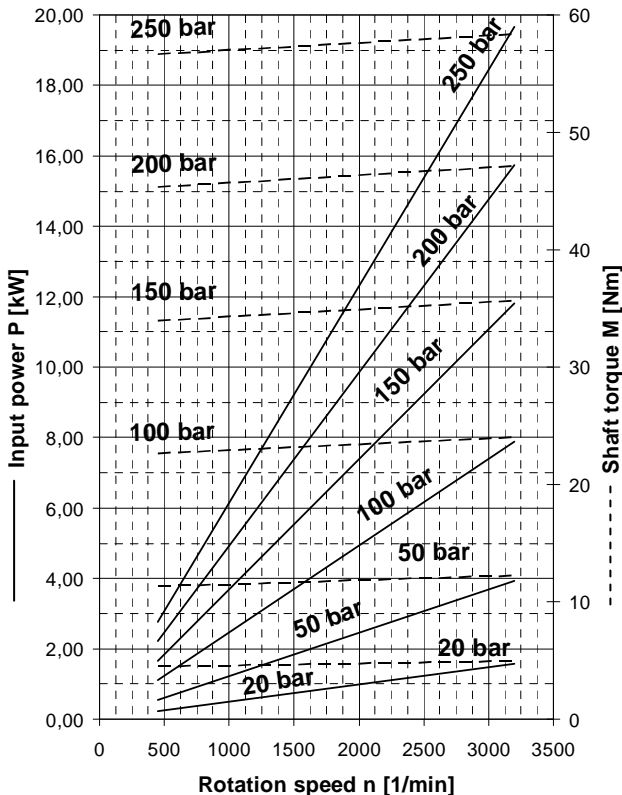

16 cm³

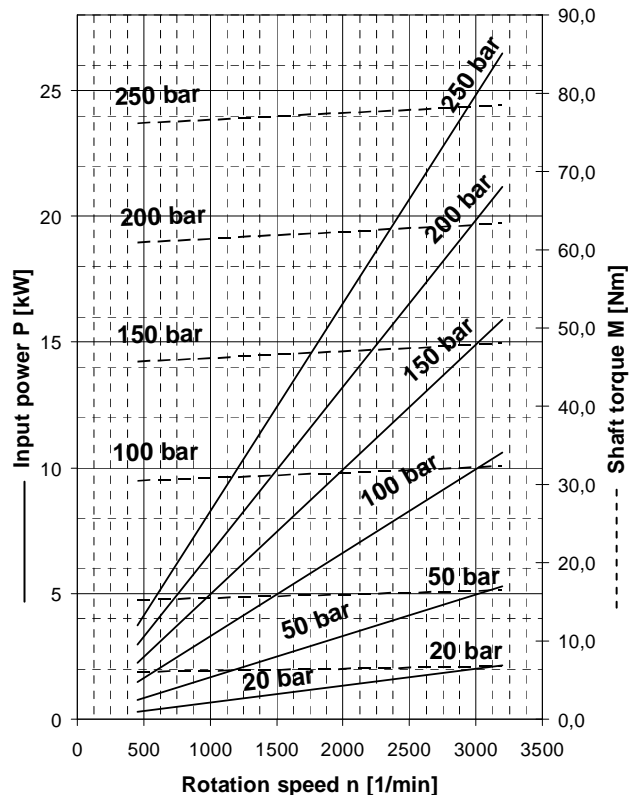

20 cm³

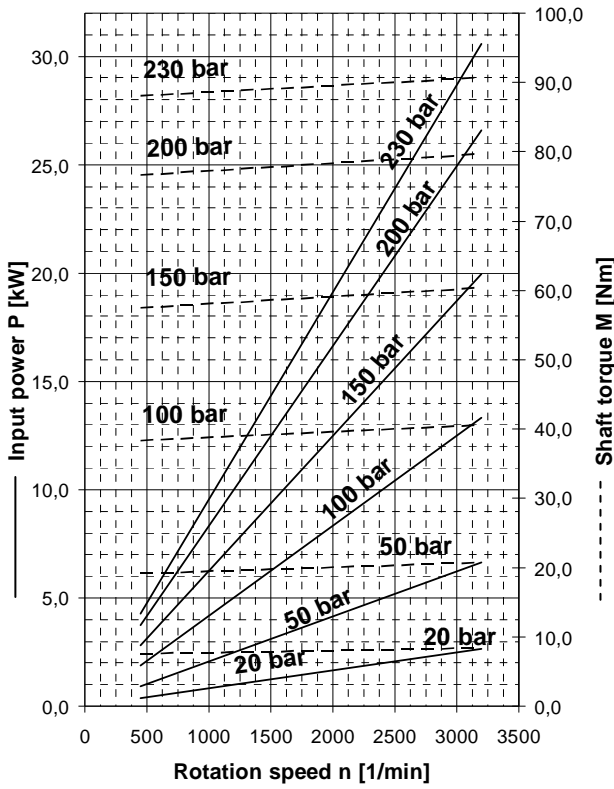

25 cm³

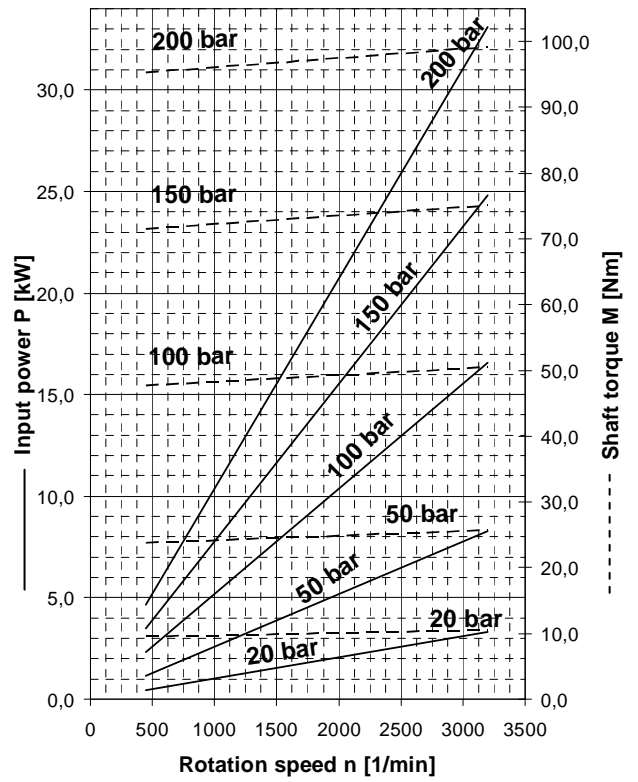

28 cm³

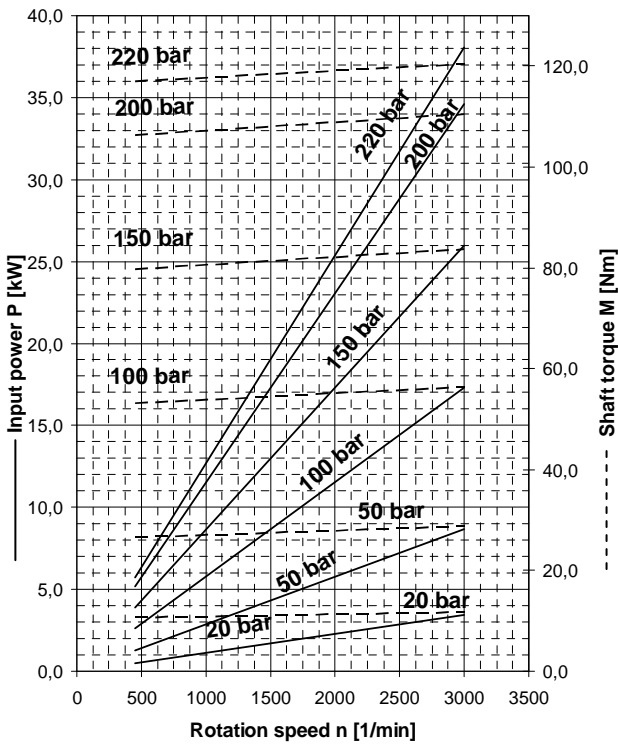

31 cm³

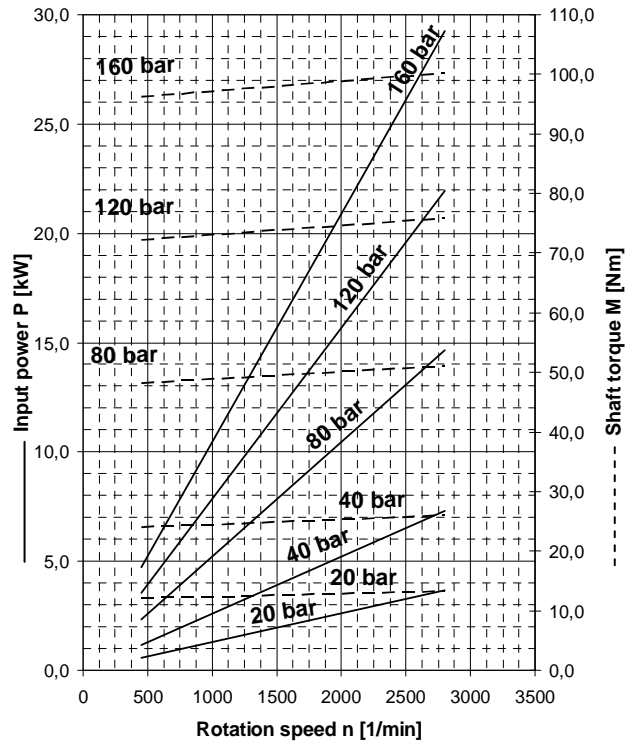

CALCULATION FORMULAS

Flow rate

$$Q = \frac{V_g \cdot n}{1000} \cdot \eta_v \quad [\text{dm}^3 \cdot \text{min}^{-1}]$$

V_g	[cm ³]	geometric pump volume
n	[min ⁻¹]	rotation speed
η_v	[-]	volumetric efficiency

Displacement

$$V_g = \frac{Q \cdot 1000}{n \cdot \eta_v} \quad [\text{cm}^3]$$

Shaft torque

$$M_k = \frac{V_g \cdot p}{20 \cdot \pi \cdot \eta_m} \quad [\text{N.m}]$$

p	[bar]	required pressure at the outlet port
η_m	[-]	mechanic efficiency

Input power

$$P = \frac{V_g \cdot n \cdot p}{600 \cdot 1000 \cdot \eta_t} \quad [\text{kW}]$$

η_t	[-]	total efficiency
----------	-----	------------------

PUMP EFFICIENCY

Volumetric efficiency η_v

Volumetric efficiency determines the amount of flow losses. Its value varies: $\eta_v = 0,92 \div 0,98$ (depending on the speed and the pressure at the pressure port). Volumetric efficiency can be expressed as follows:

$$\eta_v = \frac{Q_{\text{skut}}}{Q_{\text{teor}}} \quad [-]$$

Q_{skut}	[dm ³ ·min ⁻¹]	actual flow rate
Q_{teor}	[dm ³ ·min ⁻¹]	theoretical flow rate

Mechanical efficiency η_m

Mechanical efficiency determines the hydraulic-mechanical losses. Its value varies at about $\eta_m = 0,85$. Mechanical efficiency can be expressed as follows:

$$\eta_m = \frac{M_{\text{teor}}}{M_{\text{skut}}} \quad [-]$$

M_{skut}	[N.m]	actual shaft torque
M_{teor}	[N.m]	theoretical shaft torque

Total efficiency η_t

Total efficiency is defined as the arithmetic product of η_v and η_m and expresses the difference between the theoretical and the required actual input power:

$$\eta_t = \eta_v \cdot \eta_m = \frac{P_{\text{teor}}}{P_{\text{skut}}} \quad [-]$$

P_{skut}	[kW]	actual input power
P_{teor}	[kW]	theoretical input power

PRESSURE LOAD

p_{2N}	max. continuous pressure	maximum working pressure at which the pump can be operated without time-limitation
p_{2max}	maximum pressure	maximum short-term (max. 20s) allowable pressure
p₃	peak pressure	short-term pressure (split second) arising in case of a sudden change of the operating mode; any excess of this pressure during operation is inadmissible.

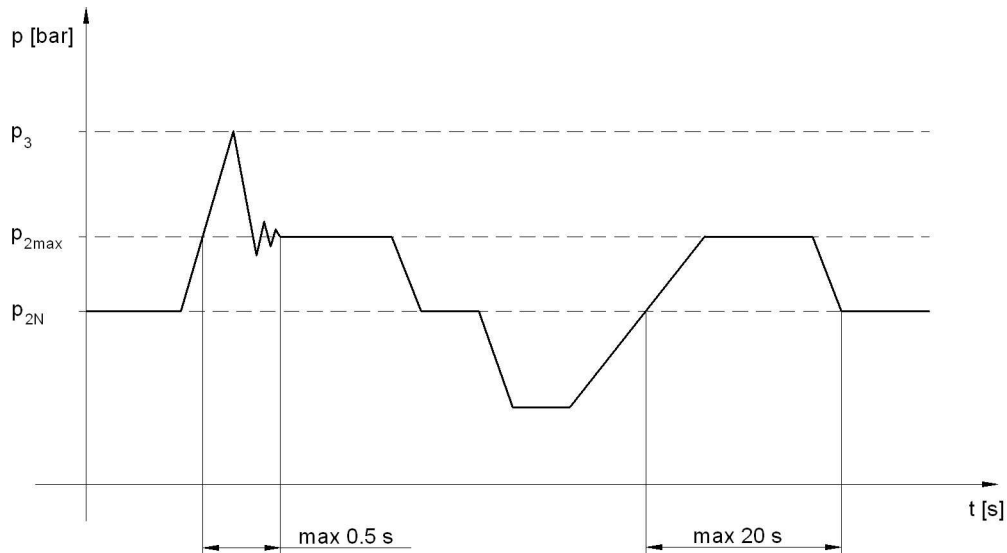

WORKING LIQUID

- Mineral oils for hydraulic drives
- Hydraulic liquids based on vegetable oils, suitable for hydrostatic drives

Liquid temperature

$t = -20 \div +80$ [°C] when used with a FKM seal (Viton) up to 120 [°C]

Cinematic viscosity

during continuous operation: $v = 20 \div 80$ [mm² · s⁻¹]
 max.: $v = 1200$ [mm² · s⁻¹]
 min.: $v = 10$ [mm² · s⁻¹]

Filtration coefficient β_{α}

$\beta_{25} 75 \geq$ (for pressure $p_2 < 200$ bar)
 $\beta_{10} 75 \geq$ (for pressure $p_2 > 200$ bar)

Contamination class ISO 4406

19/16 (for pressure $p_2 < 200$ bar)
 17/14 (for pressure $p_2 > 200$ bar)

Contamination class NAS 1638

10 (for pressure $p_2 < 200$ bar)
 8 (for pressure $p_2 > 200$ bar)

DIRECTION OF ROTATION

When determining the direction of rotation, always look at the drive shaft. The pump is allowed to be operated in the defined direction of rotation only.

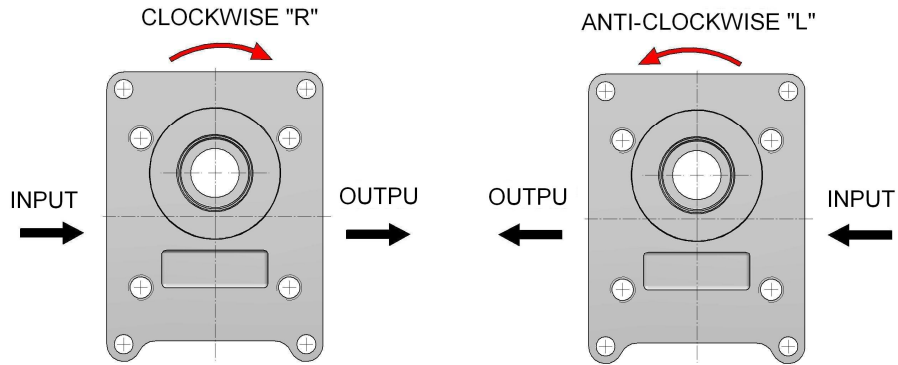

ORDER KEY – SIMPLE VERSION

UD - 16 R - R1 D1 - S G2 G1 - V . 0000

Code	Displacement [cm ³]
8,0	7,93
10,0	10,02
12,5	12,10
16,0	16,28
20,0	20,45
25,0	25,46
28,0	28,38
31,0	32,14
39,0	40,07
XX	Other displacements on request

Code	Rotation
R	Clockwise rotation
L	Anti-clockwise rotation

Code	Type
UD	UD Series Gear Pump
UDK	UD Series Gear Pump, short version
UDD	UD Series Gear Pump, reinforced version

Code	Flange design	
R1		Rectangular flange, centre ring Ø62, spacing 86x120, with O-ring
R2		Rectangular flange, centre ring Ø62, spacing 86x120
K1		„UŠATÁ“, centre ring Ø62, 2 aperture, spacing 115, with O-ring
S1		SAE A, centre ring Ø82,55, 2 aperture, spacing 130
S2		SAE B, centre ring Ø101,6, 2 aperture, spacing 174
Z		Special design

Code	Location of suction and pressure port	
S		Side (in the body)
R		Rear (in the cover)
C		Combination

Code	Drive shaft design	
C1		Taper 1:5
D1		Grooving 17x1
D2		Grooving 22x1
D3		Grooving 5/8"
D4		Grooving 22x19
D5		Grooving SAE 7/8"
D6		Straight-flanked grooving 6x18x22
D7		Straight-flanked grooving 6x23x28
K1		Cross coupling
V1		Cylindric
Z		Special design

Code	Special arrangements
-	No special arrangements
T000	Regulation type T
R000	Regulation type R
S000	Regulation type S
TL12	Regulation T, bleeder
2310	Adjustment for ND
HT36	Regulation T, With front end bearing, bleeder

Code	Sealing material
V	FPN (VITON)
N	NBR

Code	Design of suction and pressure port	
M03		Thread M 14x1,5
M05		Thread M 18x1,5
M06		Thread M 20x1,5
M07		Thread M 22x1,5
M09		Thread M 27x2
G03		Thread BSP G1/2
G04		Thread BSP G3/4
Z		Special design

Example of an indication of a left-handed UD pump; geometric volume 16 cm³; rectangular flange with center ring Ø 62 without nut for the O-ring; grooving 22x1; body inlet and outlet with metric threads; standard NBR sealing; no special arrangement: **UD-16L-R2D2-S M07/M09-N.0000**

ORDER KEY – MULTIPLE VERSION

UD - 16 / 16 R - R1 D1 - S G2 G1 / G2 G1 - V . 0000

Code	Displacement [cm ³]
8,0	7,93
10,0	10,02
12,5	12,10
16,0	16,28
20,0	20,45
25,0	25,46
28,0	28,38
31,0	32,14
39,0	40,07
XX	Other displacements on request

Code	Rotation
R	Clockwise rotation
L	Anti-clockwise rotation

Code	Type
UD	UD Series Gear Pump
UDK	UD Series Gear Pump, short version
UDD	UD Series Gear Pump, reinforced version

Code	Flange design
R1	Rectangular flange, centre ring Ø62, spacing 86x120, with O-ring
R2	Rectangular flange, centre ring Ø62, spacing 86x120
K1	„UŠATÁ“, centre ring Ø62, 2 aperture, spacing 115, with O-ring
S1	SAE A, centre ring Ø82,55, 2 aperture, spacing 130
S2	SAE B, centre ring Ø101,6, 2 aperture, spacing 174
Z	Special design

Code	Location of suction and pressure port
S	Side (in the body)
C	Combination

Code	Drive shaft design
C1	Taper 1:5
D1	Grooving 17x1
D2	Grooving 22x1
D3	Grooving 5/8"
D4	Grooving 22x19
D5	Grooving SAE 7/8"
D6	Straight-flanked grooving 6x18x22
D7	Straight-flanked grooving 6x23x28
K1	Cross coupling
V1	Cylindric
Z	Special design

Code	Special arrangements
-	No special arrangements
T000	Regulation type T
R000	Regulation type R
S000	Regulation type S
TL12	Regulation T, bleeder
2310	Adjustment for ND
HT36	Regulation T, With front end bearing, bleeder

Code	Sealing material
V	FPN (VITON)
N	NBR

Code	Design of suction and pressure port
M03	Thread M 14x1,5
M05	Thread M 18x1,5
M06	Thread M 20x1,5
M07	Thread M 22x1,5
M09	Thread M 27x2
G03	Thread BSP G1/2
G04	Thread BSP G3/4
Z	Special design

Example of an indication of a left-handed UD pump with two sections; geometric volumes 20 and 16 cm³, rectangular flange with center ring Ø62 without nut for the O-ring; grooving 22x1; body inlets and outlets with metric threads; standard NBR sealing; no special arrangement: **UD-20/16L-R2D2-S M07/M09-N.0000**

DESIGN OF FLANGES, DRIVE SHAFTS AND INLET PORTS

Flanges

R1:

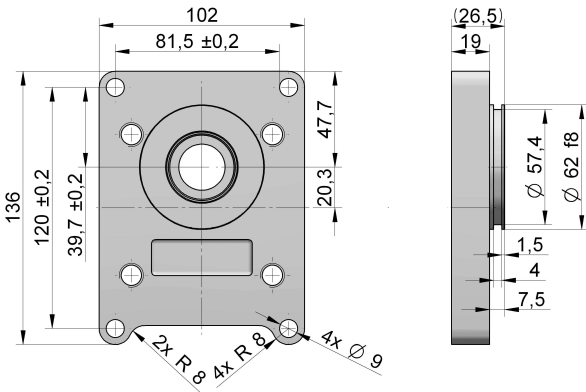

R2:

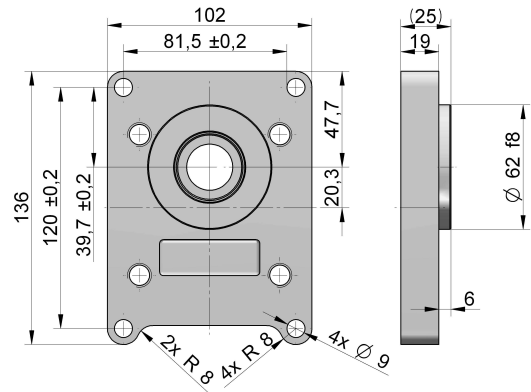

K1:

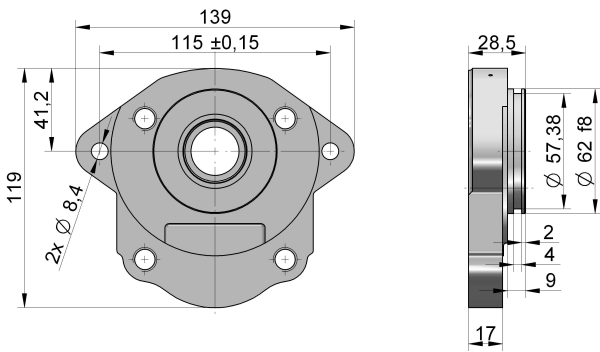

S1:

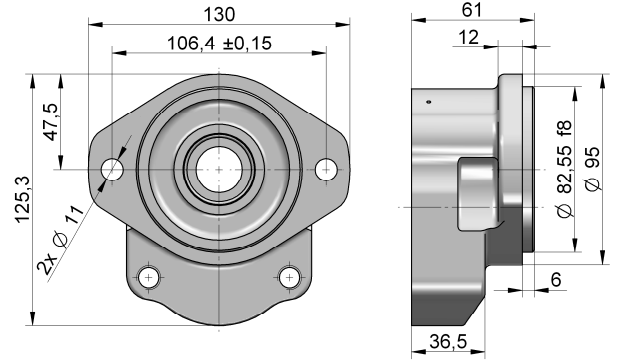

S2:

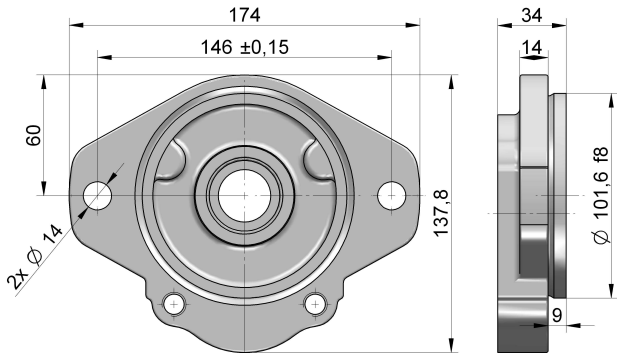

Drive shafts

C1:

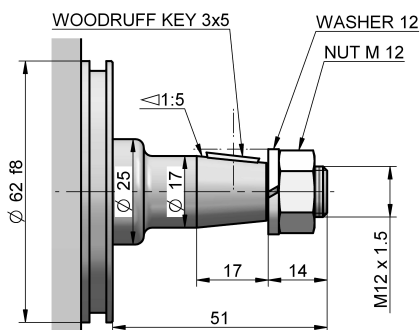

D1:

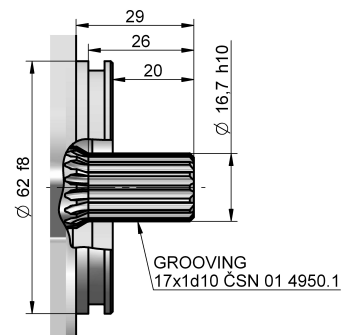

D2:

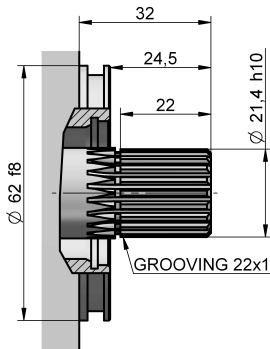

D3:

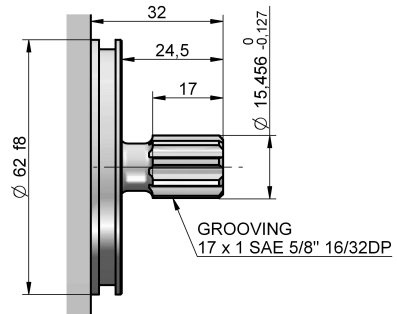

D4:

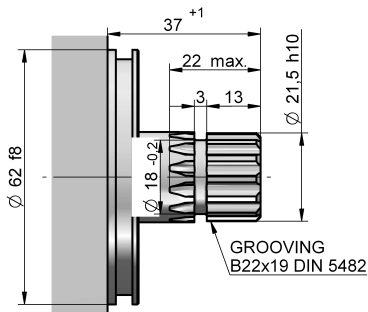

D5:

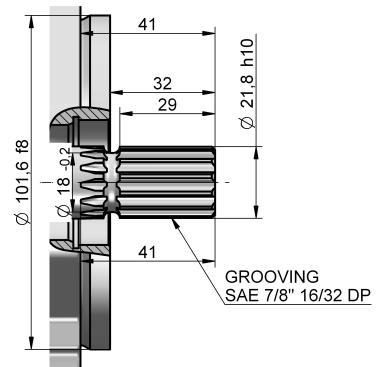

D6:

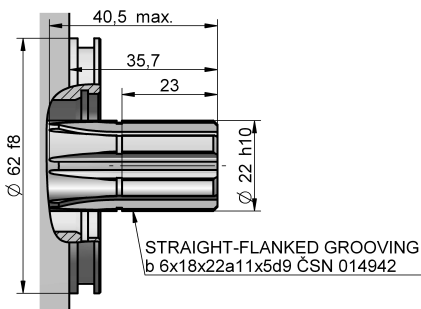

D7:

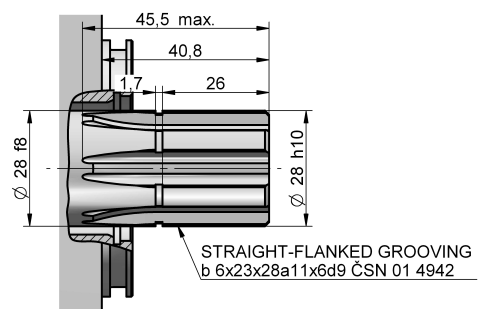

K1:

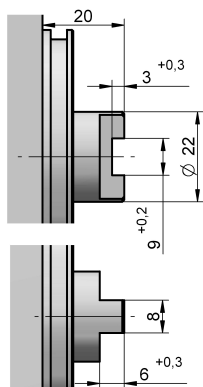

V1:

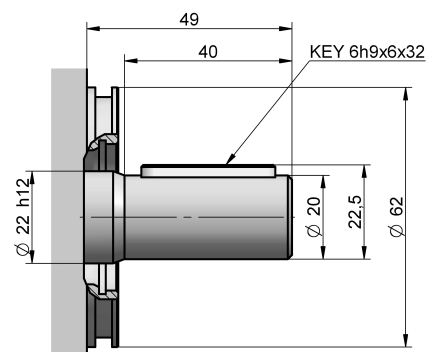

INLET AND OUTLET PORTS

Metric thread ISO 6149

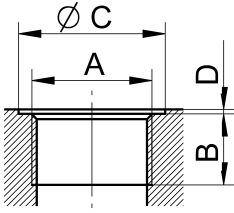

Code	A	B	C	D
M03	M14x1,5	14	20	1
M05	M18x1,5	14	24	1
M06	M20x1,5	14	25	1
M07	M22x1,5	14	28	1
M09	M27x2	16	33	1

BSP pipe thread ISO 228 - 1

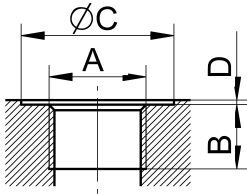

Code	A	B	C	D
G03	G 1/2	14	28	1
G04	G 3/4	17	33	1

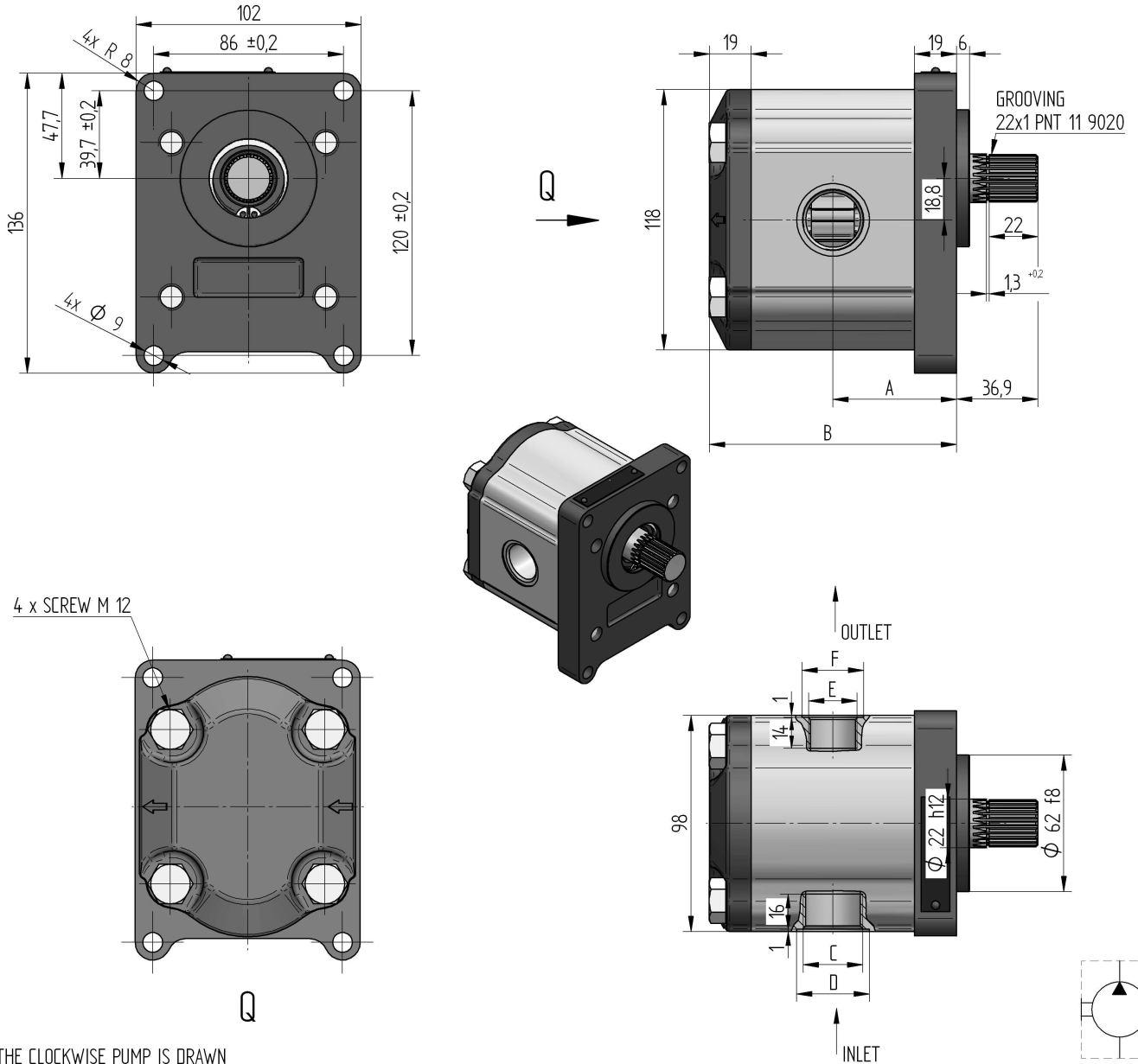

THE CLOCKWISE PUMP IS DRAWN

UD-31R-R1D2-S M07M09-N.0000	183 9476	R	31	200	450	2800	65,50	131,0	M27x2	Ø 33	M22x1,5	Ø 28	
UD-31L-R1D2-S M07M09-N.0000	183 9047	L											
UD-28R-R1D2-S M07M09-N.0000		R	28	230	450	3000	63,25	126,5	M27x2	Ø 33	M22x1,5	Ø 28	
UD-28L-R1D2-S M07M09-N.0000		L											
UD-25R-R1D2-S M07M09-N.0000	183 9475	R	25	250	450	3200	61,50	123,0	M27x2	Ø 33	M22x1,5	Ø 28	
UD-25L-R1D2-S M07M09-N.0000	183 9046	L											
UD-20R-R1D2-S M07M09-N.0000	183 9412	R	20	270	450	3200	58,50	117,0	M27x2	Ø 33	M22x1,5	Ø 28	
UD-20L-R1D2-S M07M09-N.0000	183 9413	L											
UD-16R-R1D2-S M07M09-N.0000	183 9406	R	16	290	450	3200	56,00	112,0	M27x2	Ø 33	M22x1,5	Ø 28	
UD-16L-R1D2-S M07M09-N.0000	183 9407	L											
UD-12,5R-R1D2-S M07M09-N.0000		R	12,5	300	450	3200	53,50	107,0	M27x2	Ø 33	M22x1,5	Ø 28	
UD-12,5L-R1D2-S M07M09-N.0000		L											
UD-10R-R1D2-S M07M09-N.0000	183 9400	R	10	300	450	3200	52,25	104,5	M27x2	Ø 33	M22x1,5	Ø 28	
UD-10L-R1D2-S M07M09-N.0000	183 9401	L											
UD-8R-R1D2-S M07M09-N.0000		R	8	300	600	3200	51,00	102,0	M27x2	Ø 33	M22x1,5	Ø 28	
UD-8L-R1D2-S M07M09-N.0000		L											
ORDER KEY	PURCH. CODE	DIRECT. OF ROT.	DISPLACEMENT [cm ³ /1]	CONT. PRESS. [bar]	MIN. SPEED [min ⁻¹]	MAX. SPEED [min ⁻¹]	A	B	C	D	E	F	
DIMENSION [mm]													

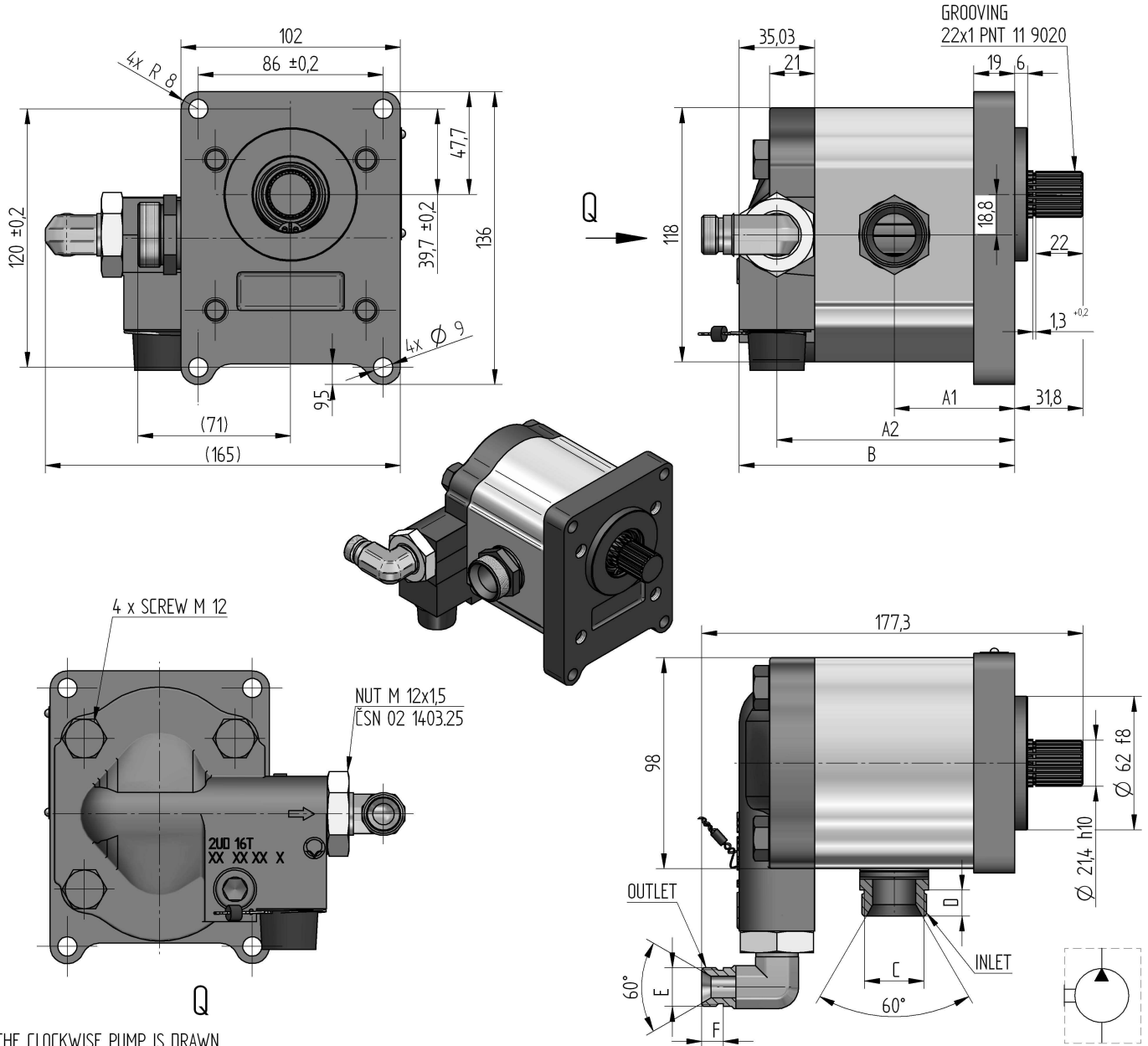

THE CLOCKWISE PUMP IS DRAWN

UD-31R-R2 D2-S ZZ-V.T64V		R	31	200	450	2800	65,50	129,5	147,0	M30x2	Ø 14	M18x1,5	Ø 10
UD-31L-R2 D2-S ZZ-V.T64V		L	31	200	450	2800	65,50	129,5	147,0	M30x2	Ø 14	M18x1,5	Ø 10
UD-28R-R2 D2-S ZZ-V.T64V		R	28	230	450	3000	63,25	125,0	142,5	M30x2	Ø 14	M18x1,5	Ø 10
UD-28L-R2 D2-S ZZ-V.T64V		L	28	230	450	3000	63,25	125,0	142,5	M30x2	Ø 14	M18x1,5	Ø 10
UD-25R-R2 D2-S ZZ-V.T64V	183 9637	R	25	250	450	3200	61,50	121,5	139,0	M30x2	Ø 14	M18x1,5	Ø 10
UD-25L-R2 D2-S ZZ-V.T64V		L	25	250	450	3200	61,50	121,5	139,0	M30x2	Ø 14	M18x1,5	Ø 10
UD-20R-R2 D2-S ZZ-V.T64V	183 9742	R	20	270	450	3200	58,50	115,5	133,0	M30x2	Ø 14	M18x1,5	Ø 10
UD-20L-R2 D2-S ZZ-V.T64V		L	20	270	450	3200	58,50	115,5	133,0	M30x2	Ø 14	M18x1,5	Ø 10
UD-16R-R2 D2-S ZZ-V.T64V	183 9633	R	16	290	450	3200	56,00	110,5	128,0	M30x2	Ø 14	M18x1,5	Ø 10
UD-16L-R2 D2-S ZZ-V.T64V		L	16	290	450	3200	56,00	110,5	128,0	M30x2	Ø 14	M18x1,5	Ø 10
UD-12,5R-R2 D2-S ZZ-V.T64V		R	12,5	300	450	3200	53,50	105,5	123,0	M30x2	Ø 14	M18x1,5	Ø 10
UD-12,5L-R2 D2-S ZZ-V.T64V		L	12,5	300	450	3200	53,50	105,5	123,0	M30x2	Ø 14	M18x1,5	Ø 10
UD-10R-R2 D2-S ZZ-V.T64V		R	10	300	450	3200	52,25	103,0	120,5	M30x2	Ø 14	M18x1,5	Ø 10
UD-10L-R2 D2-S ZZ-V.T64V		L	10	300	450	3200	52,25	103,0	120,5	M30x2	Ø 14	M18x1,5	Ø 10
UD-8R-R2 D2-S ZZ-V.T64V		R	8	300	600	3200	51,00	100,5	118,0	M30x2	Ø 14	M18x1,5	Ø 10
UD-8L-R2 D2-S ZZ-V.T64V		L	8	300	600	3200	51,00	100,5	118,0	M30x2	Ø 14	M18x1,5	Ø 10
ORDER KEY	PURCH. CODE	DIRECT. OF ROT.	DISPLACEMENT [cm ³ /1]	CONT. PRESS. [bar]	MIN. SPEED [min ⁻¹]	MAX. SPEED [min ⁻¹]	A	B	C	D	E	F	G
DIMENSION [mm]													

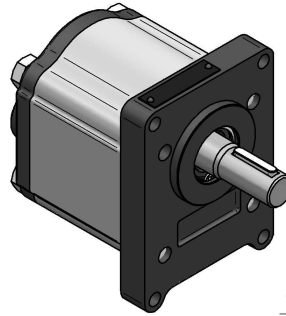
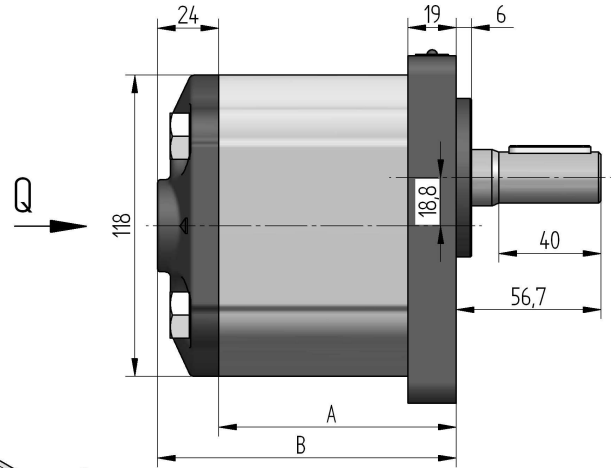
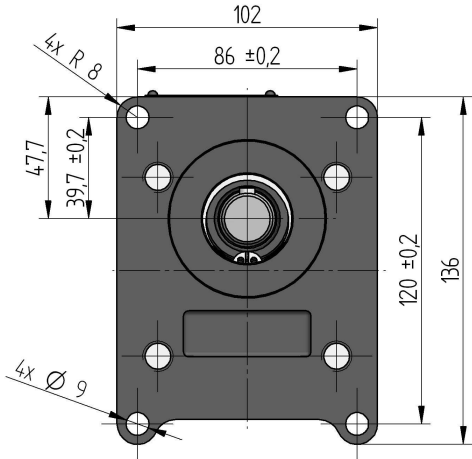

4 x SCREW M 12

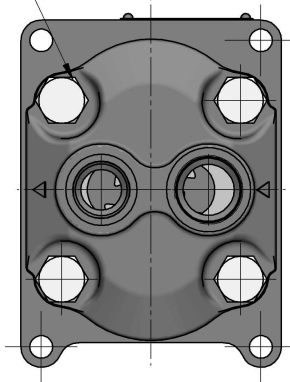

SQUARE KEY 6h9x6x32
ČSN 02 2562

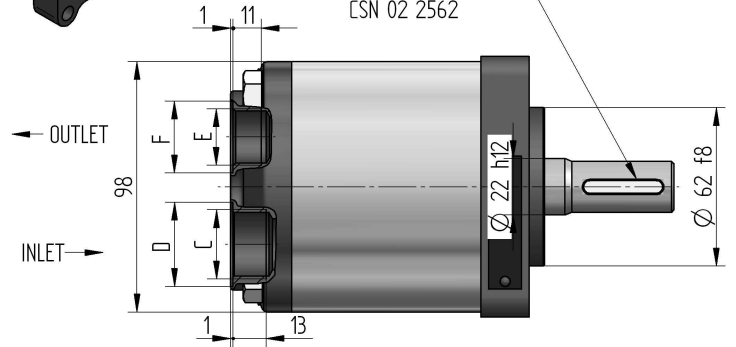

Q

THE CLOCKWISE PUMP IS DRAWN

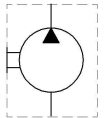

UD-31R-R2 V1-R M09M07-N.A050		R	31	200	450	2800	112,0	136,0	M27x2	Ø 33	M22x1,5	Ø 28	
UD-31L-R2 V1-R M09M07-N.AL05		L											
UD-28R-R2 V1-R M09M07-N.A050		R	28	230	450	3000	107,5	131,5	M27x2	Ø 33	M22x1,5	Ø 28	
UD-28L-R2 V1-R M09M07-N.AL05		L											
UD-25R-R2 V1-R M09M07-N.A050		R	25	250	450	3200	104,0	128,0	M27x2	Ø 33	M22x1,5	Ø 28	
UD-25L-R2 V1-R M09M07-N.AL05		L											
UD-20R-R2 V1-R M09M07-N.A050		R	20	270	450	3200	98,0	122,0	M27x2	Ø 33	M22x1,5	Ø 28	
UD-20L-R2 V1-R M09M07-N.AL05		L											
UD-16R-R2 V1-R M09M07-N.A050		R	16	290	450	3200	93,0	117,0	M27x2	Ø 33	M22x1,5	Ø 28	
UD-16L-R2 V1-R M09M07-N.AL05		L											
UD-12,5R-R2 V1-R M09M07-N.A050		R	12,5	300	450	3200	88,0	112,0	M27x2	Ø 33	M22x1,5	Ø 28	
UD-12,5L-R2 V1-R M09M07-N.AL05		L											
UD-10R-R2 V1-R M09M07-N.A050	183 9404	R	10	300	450	3200	85,5	109,5	M27x2	Ø 33	M22x1,5	Ø 28	
UD-10L-R2 V1-R M09M07-N.AL05		L											
UD-8R-R2 V1-R M09M07-N.A050		R	8	300	600	3200	83,0	107,0	M27x2	Ø 33	M22x1,5	Ø 28	
UD-8L-R2 V1-R M09M07-N.AL05		L											
ORDER KEY	PURCH. CODE	DIRECT. OF ROT.	DISPLACEMENT [cm ³ /1]	CONT. PRESS. [bar]	MIN. SPEED [min ⁻¹]	MAX. SPEED [min ⁻¹]	A	B	C	DIMENSION [mm]			

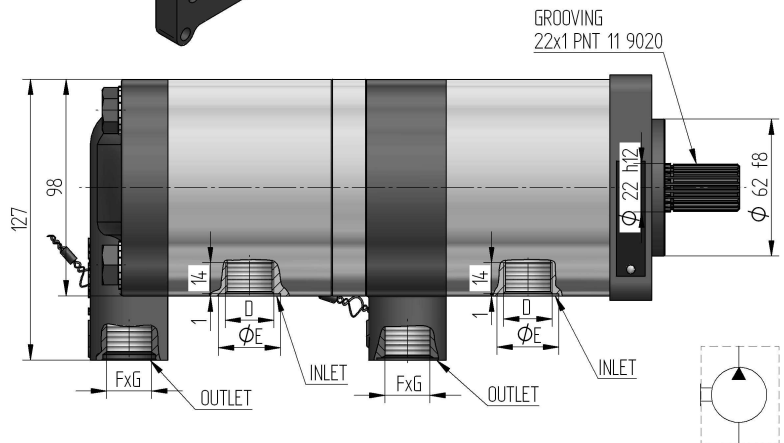
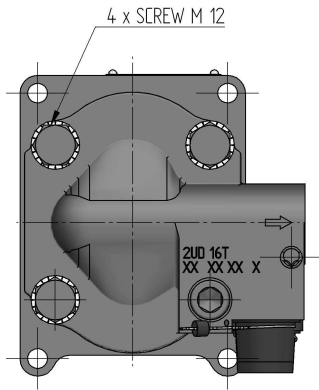
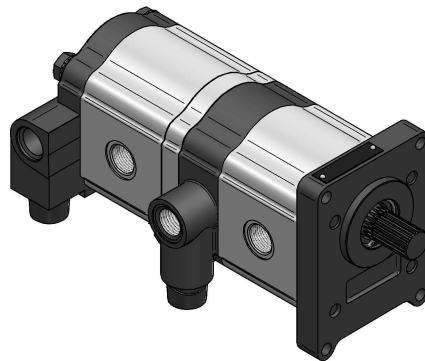
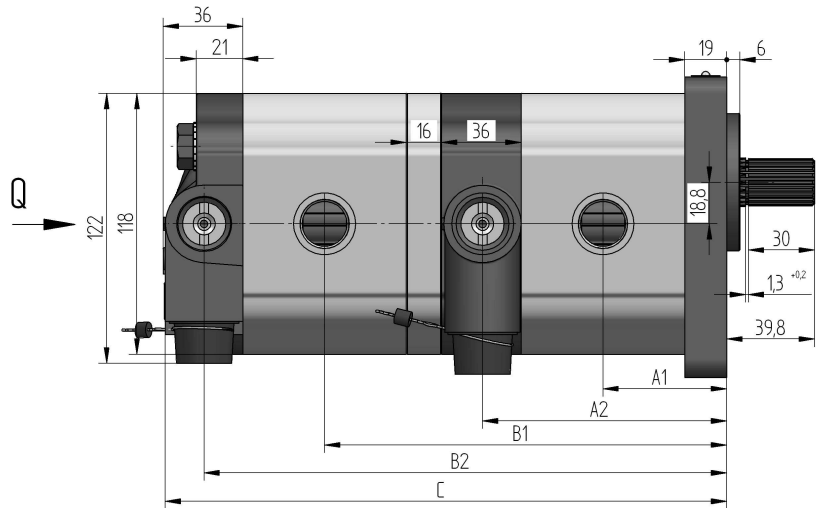
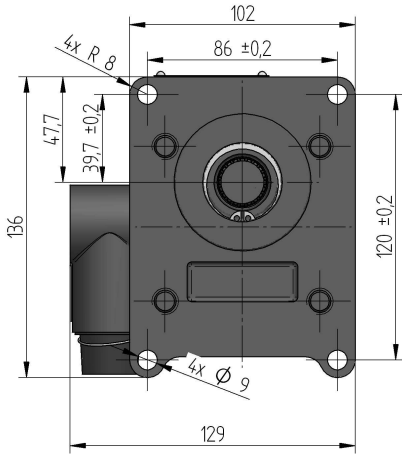

Q

THE CLOCKWISE PUMP IS DRAWN

UD-31/31R-R2 D2-S M07 M07/ M07 M07-N.T450		R	31	200	450	2800	65,50	129,5	210,50	274,5	293,0	M22x1,5	28	M22x1,5	28
UD-31/31L-R2 D2-S M07 M07/ M07 M07-N.T450		L													
UD-28/28R-R2 D2-S M07 M07/ M07 M07-N.T450		R	28	230	450	3000	63,25	125,0	203,75	265,5	284,0	M22x1,5	28	M22x1,5	28
UD-28/28L-R2 D2-S M07 M07/ M07 M07-N.T450		L													
UD-25/25R-R2 D2-S M07 M07/ M07 M07-N.T450		R	25	250	450	3200	61,50	121,5	198,50	258,5	277,0	M22x1,5	28	M22x1,5	28
UD-25/25L-R2 D2-S M07 M07/ M07 M07-N.T450		L													
UD-20/20R-R2 D2-S M07 M07/ M07 M07-N.T450		R	20	270	450	3200	58,50	115,5	189,50	246,5	265,0	M22x1,5	28	M22x1,5	28
UD-20/20L-R2 D2-S M07 M07/ M07 M07-N.T450		L													
UD-16/16R-R2 D2-S M07 M07/ M07 M07-N.T450	183 9645	R	16	290	450	3200	56,00	110,5	182,00	236,5	255,0	M22x1,5	28	M22x1,5	28
UD-16/16L-R2 D2-S M07 M07/ M07 M07-N.T450		L													
UD-12,5/12,5R-R2 D2-S M07 M07/ M07 M07-N.T450		R	12,5	300	450	3200	53,50	105,5	174,50	226,5	245,0	M22x1,5	28	M22x1,5	28
UD-12,5/12,5L-R2 D2-S M07 M07/ M07 M07-N.T450		L													
UD-10/10R-R2 D2-S M07 M07/ M07 M07-N.T450		R	10	300	450	3200	52,25	103,0	170,75	221,5	240,0	M22x1,5	28	M22x1,5	28
UD-10/10L-R2 D2-S M07 M07/ M07 M07-N.T450		L													
UD-8/8R-R2 D2-S M07 M07/ M07 M07-N.T450		R	8	300	600	3200	51,00	100,5	167,00	216,5	265,0	M22x1,5	28	M22x1,5	28
UD-8/8L-R2 D2-S M07 M07/ M07 M07-N.T450		L													
ORDER KEY	PURCH. CODE	DIRECT. OF ROT.	DISPLA- CEMENT [cm³/1]	CONT. PRESS. [bar]	MIN. SPEED [min ⁻¹]	MAX. SPEED [min ⁻¹]	A1	A2	B1	B2	C	DIMENSION [mm]			
												D	E	F	G